

**ACCESSIBLE WC TO BE WATERPROOFED IN ACCORDANCE WITH AS 3740 AND BCA REQUIREMENTS
ALL FIXTURES AND FITTINGS EXCEPT SHOWER TO BE INSTALLED IN ACCORDANCE WITH AS 1428.1 - 2009**

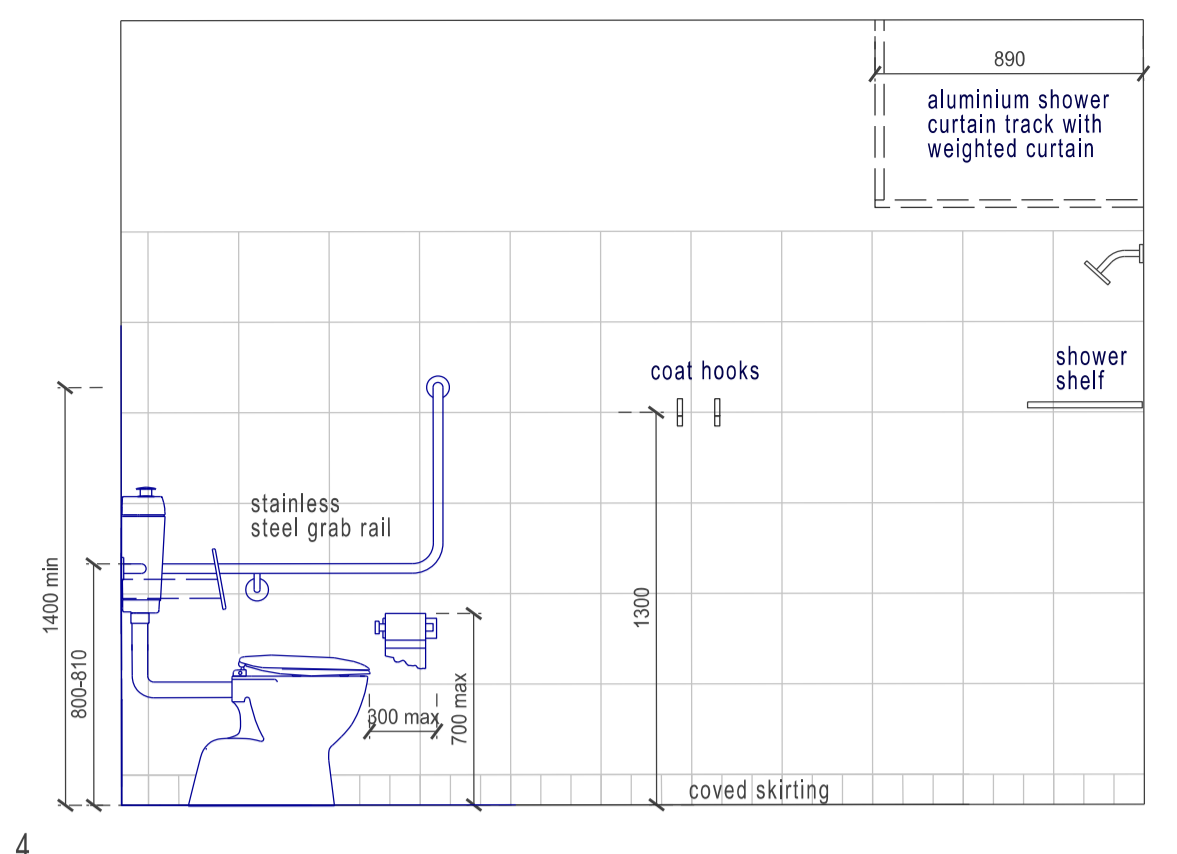

ALL FLOOR AND WALL TILES TO HAVE EPOXY GROUT AS SPECIFIED

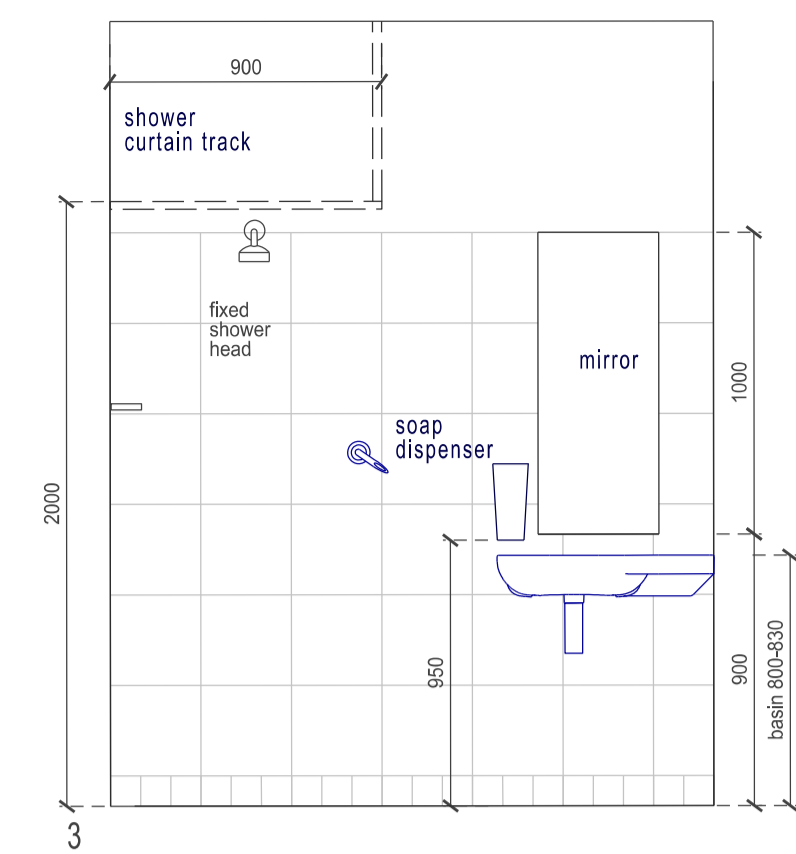
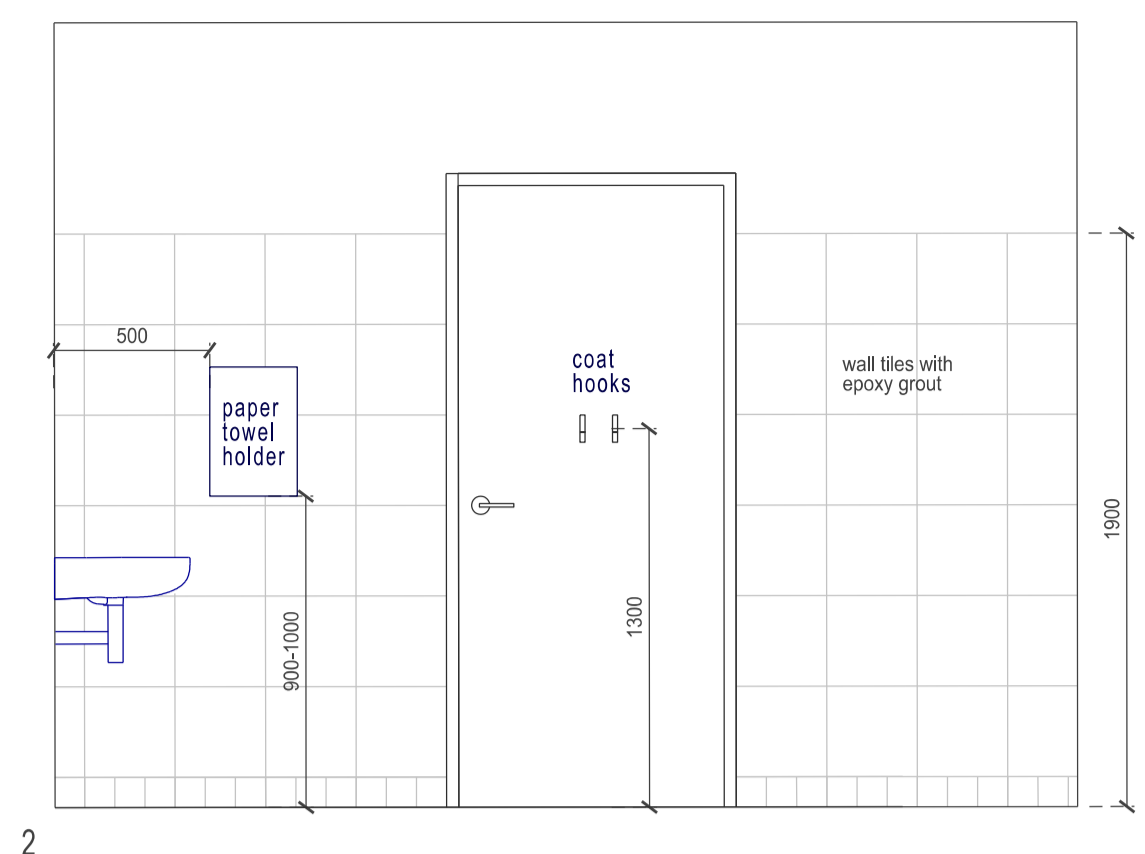
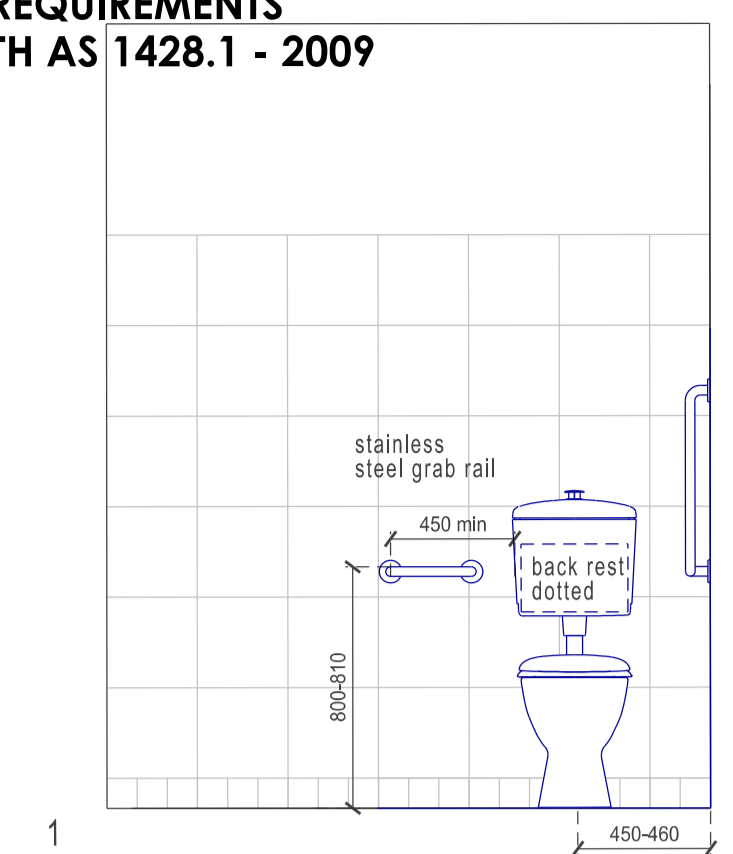
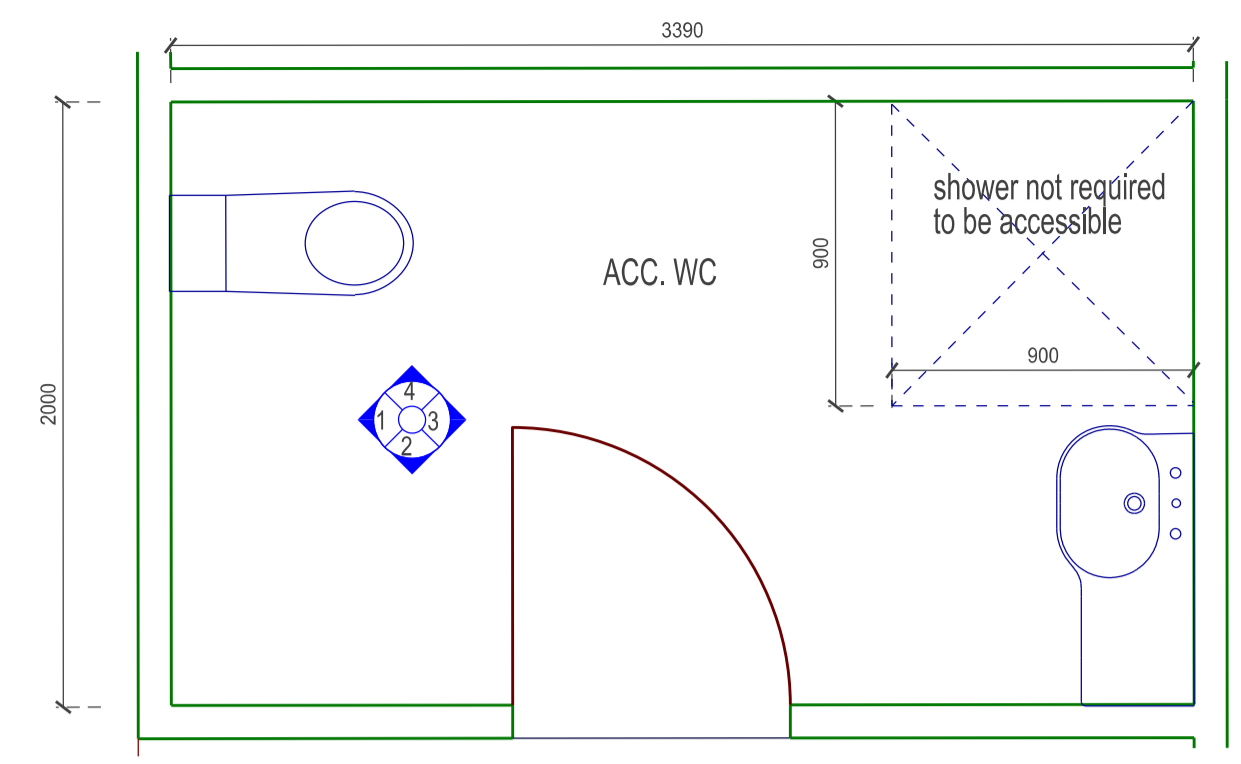
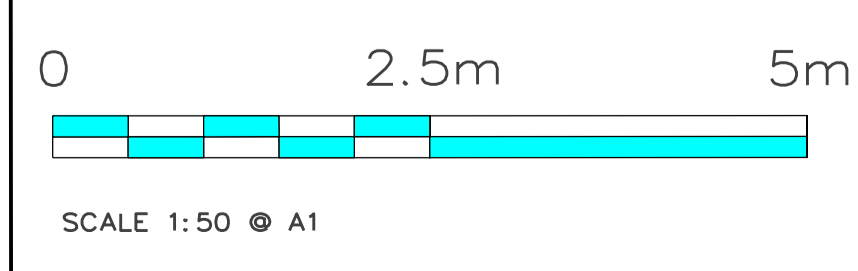
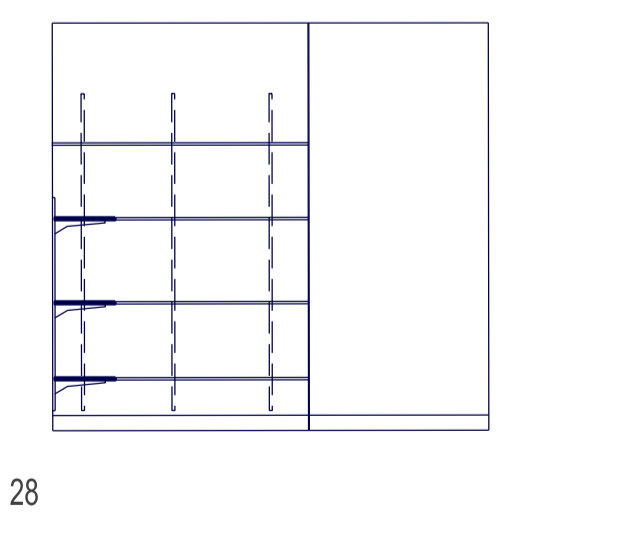
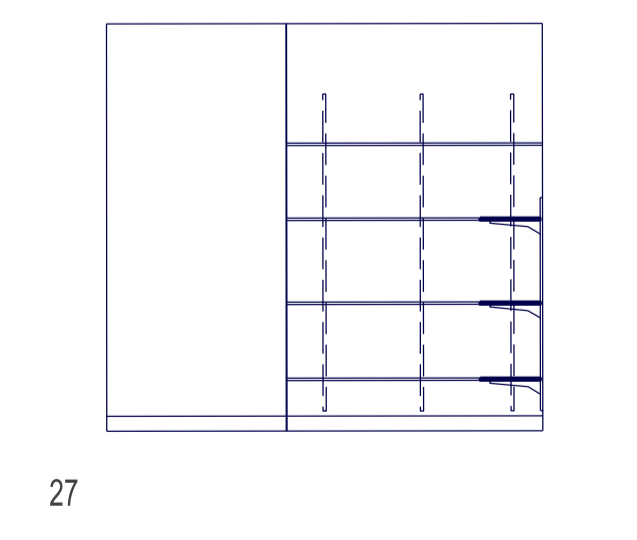
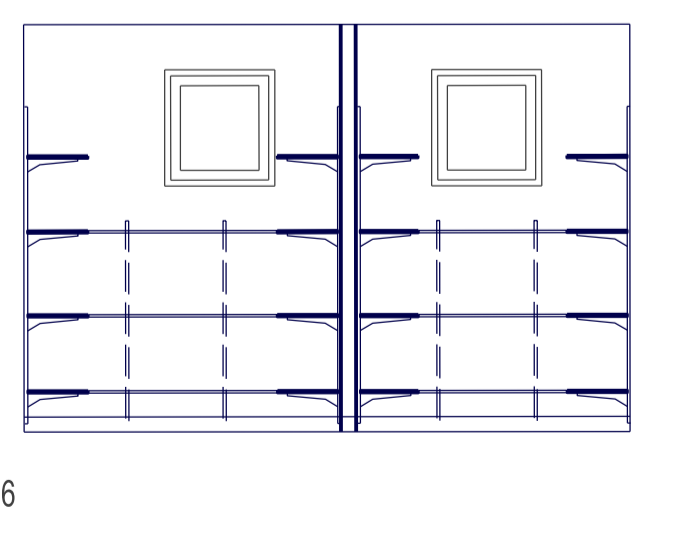
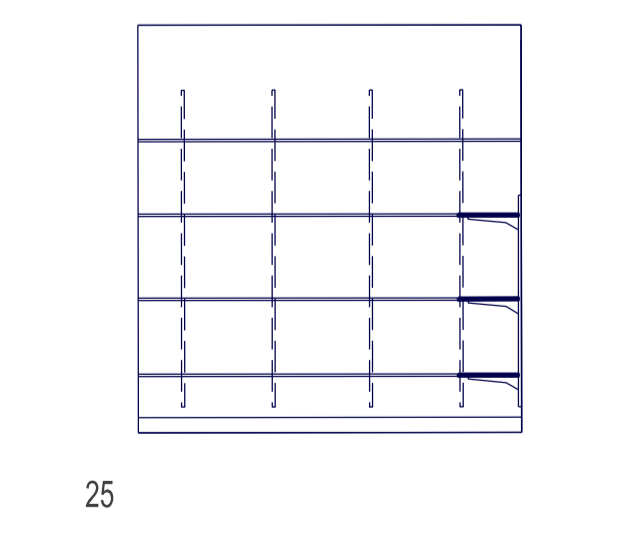
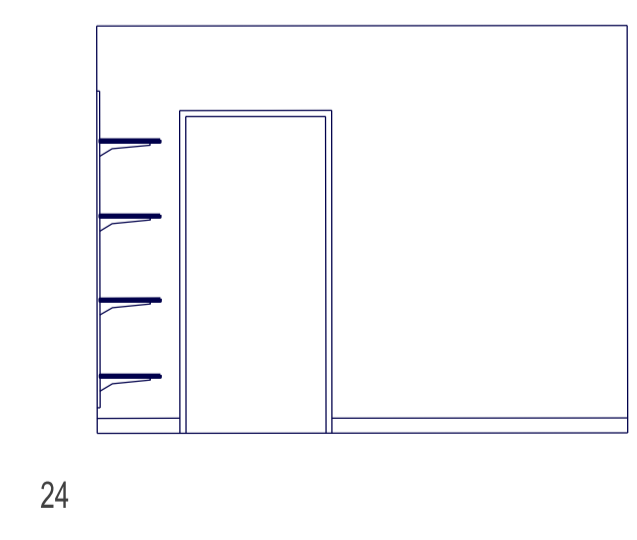
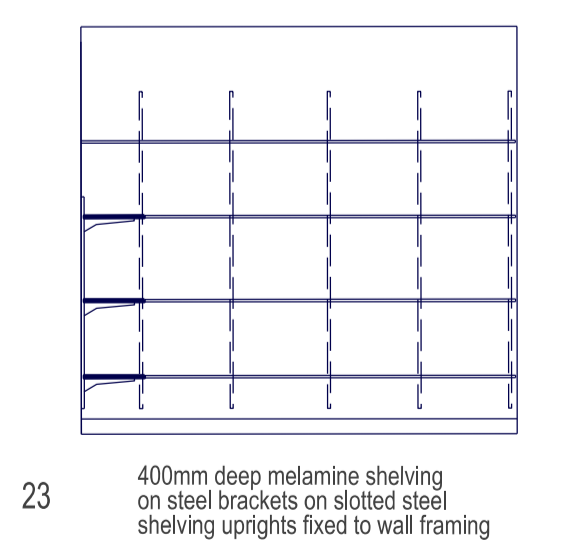
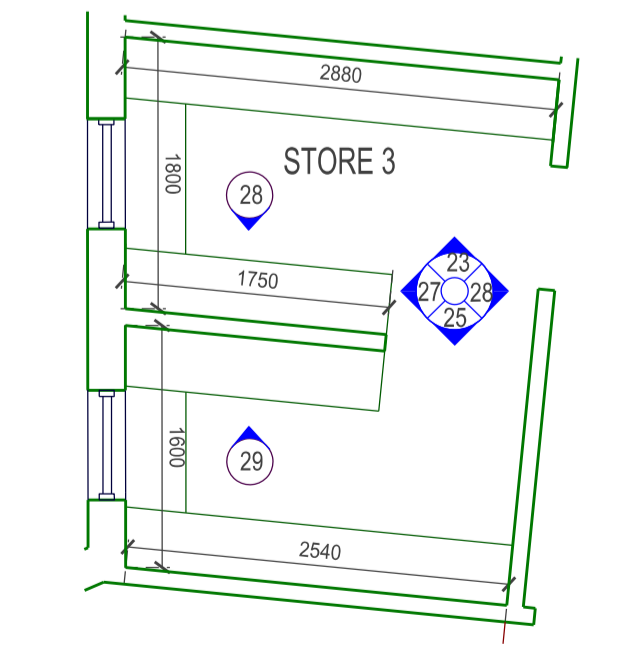
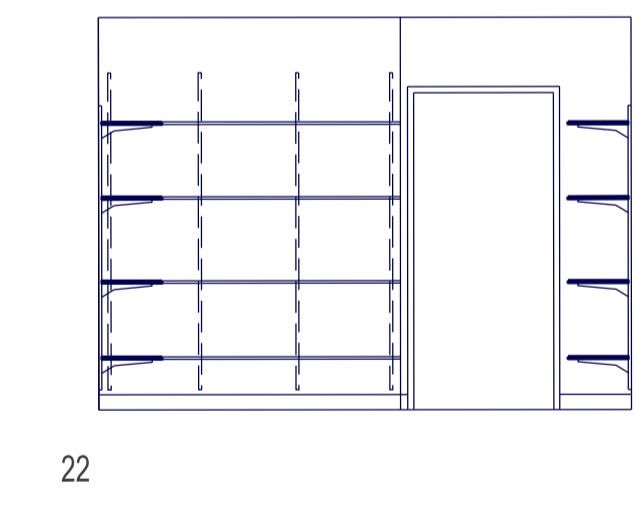
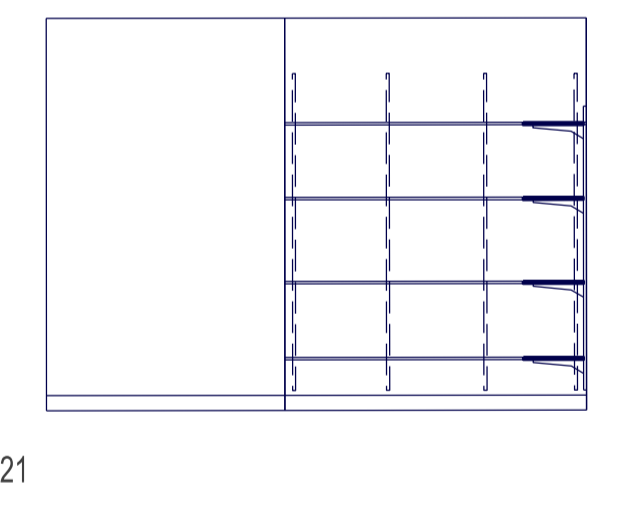
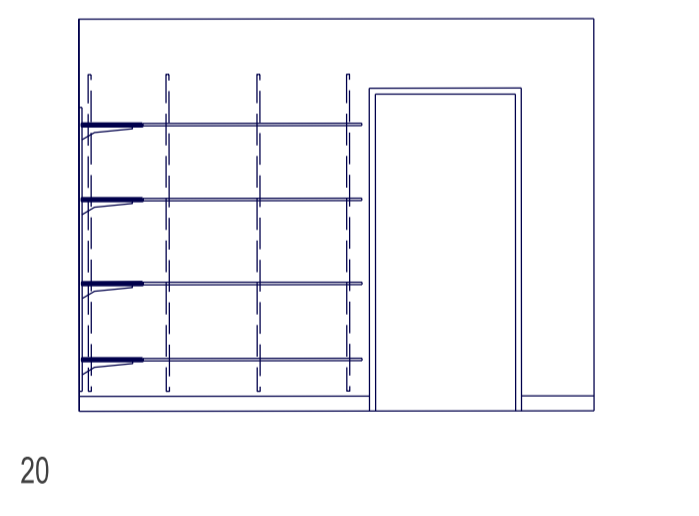
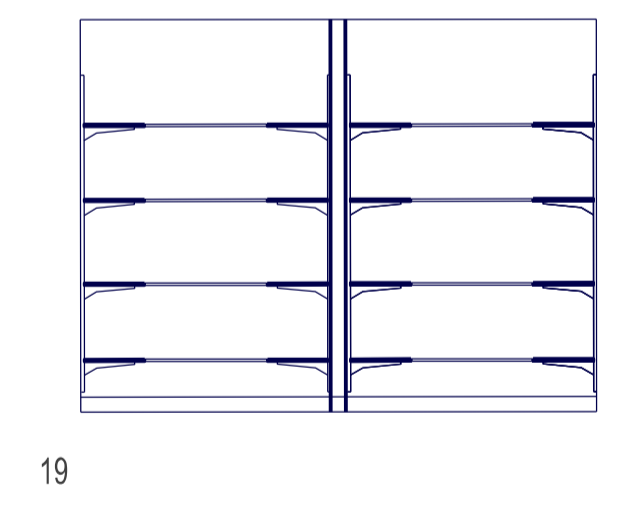
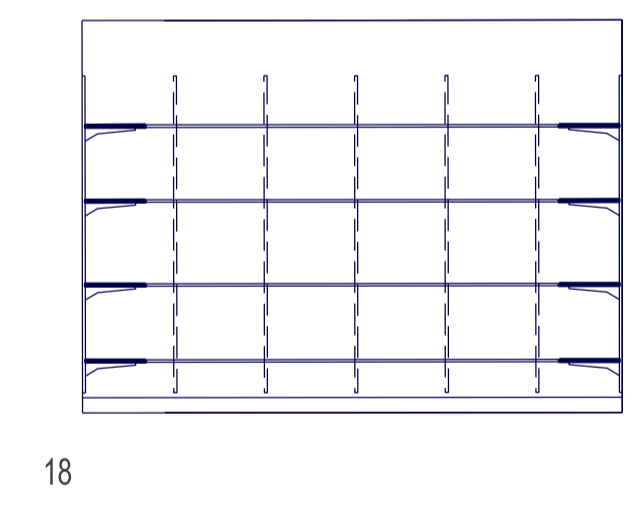
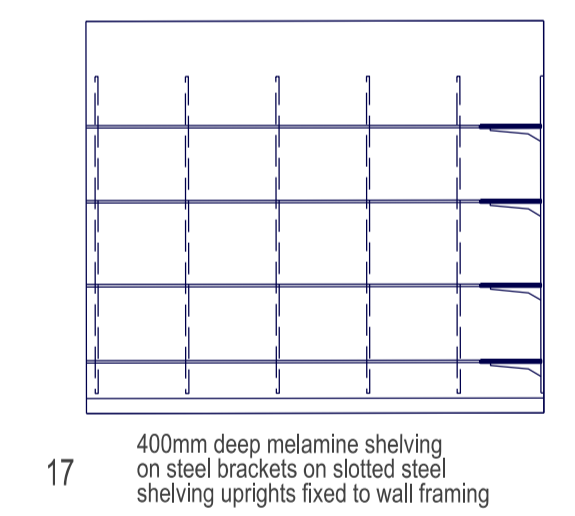
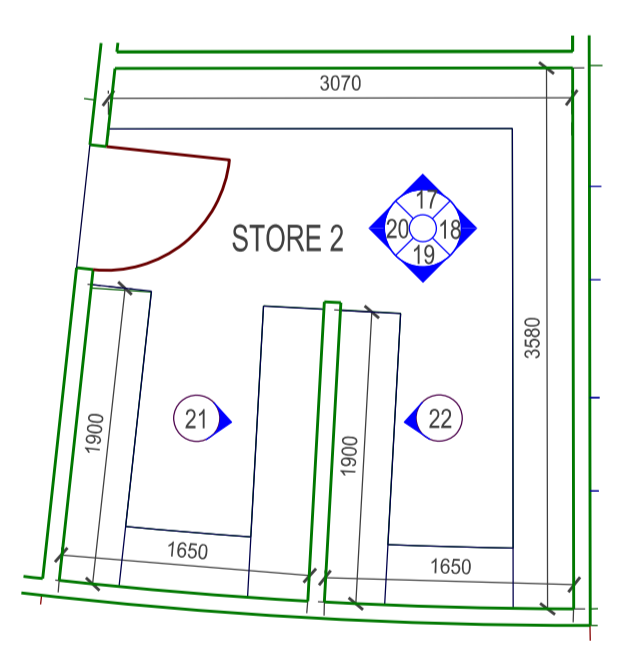
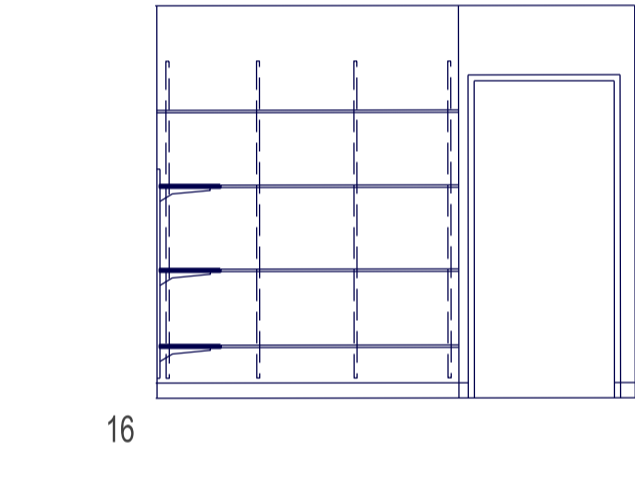
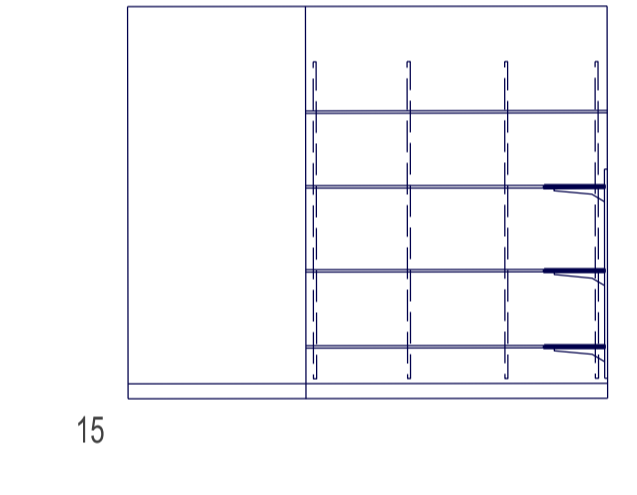
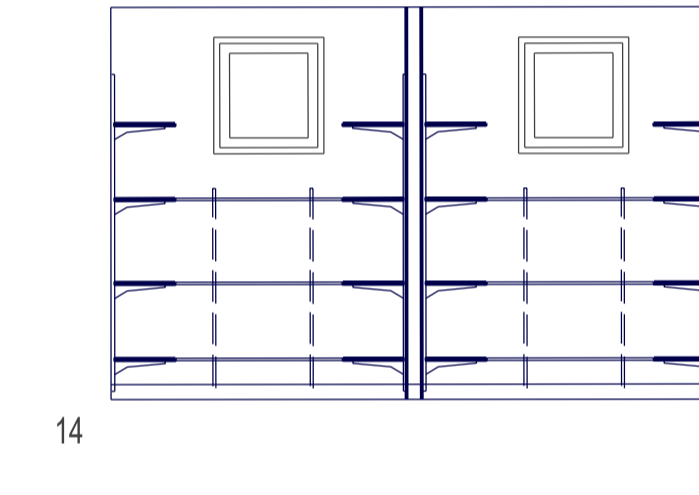
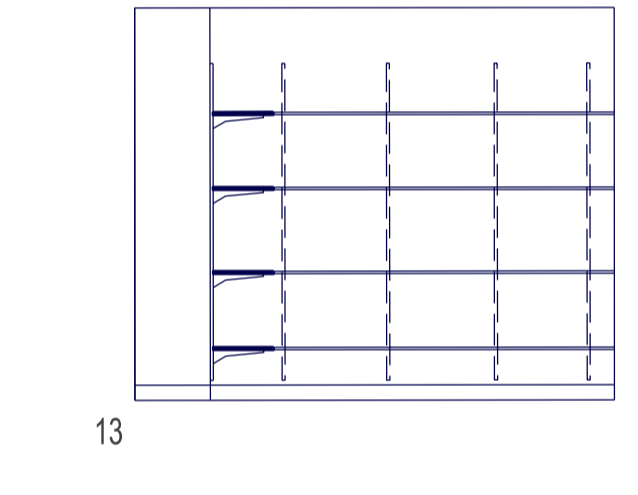
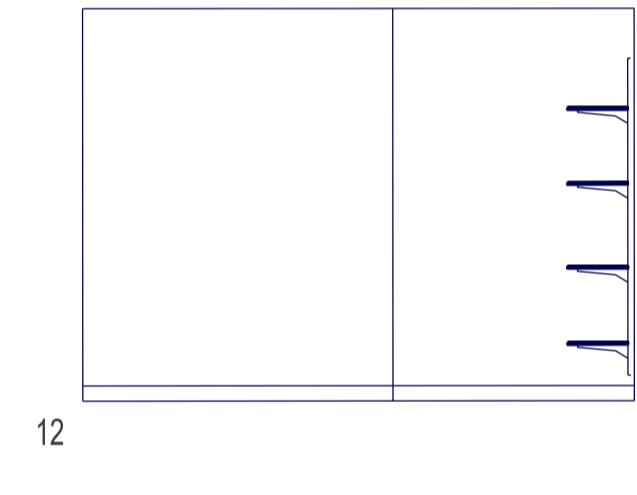
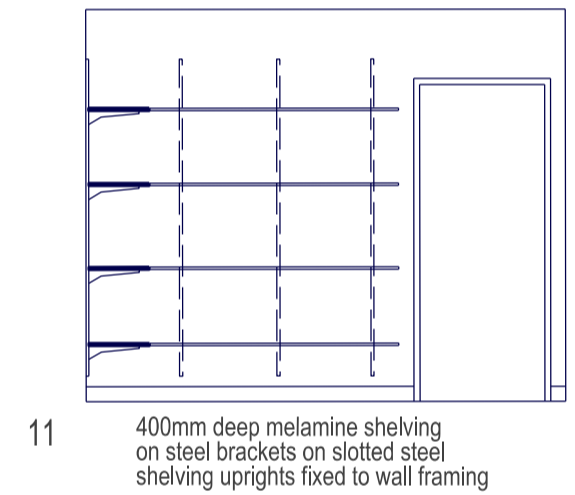
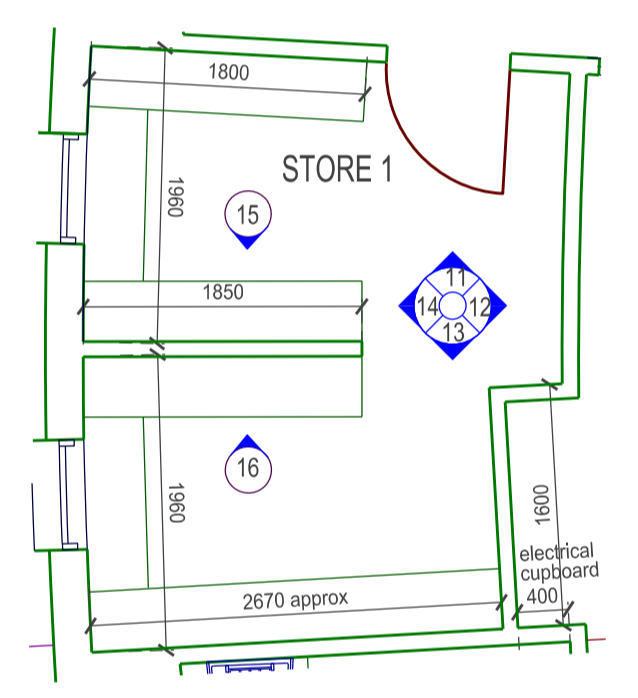
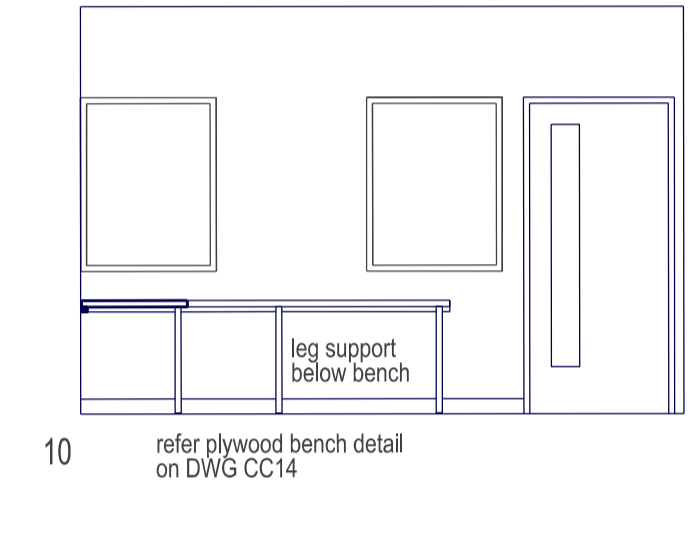
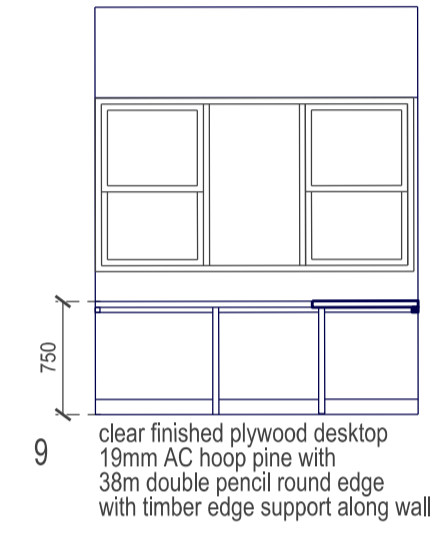
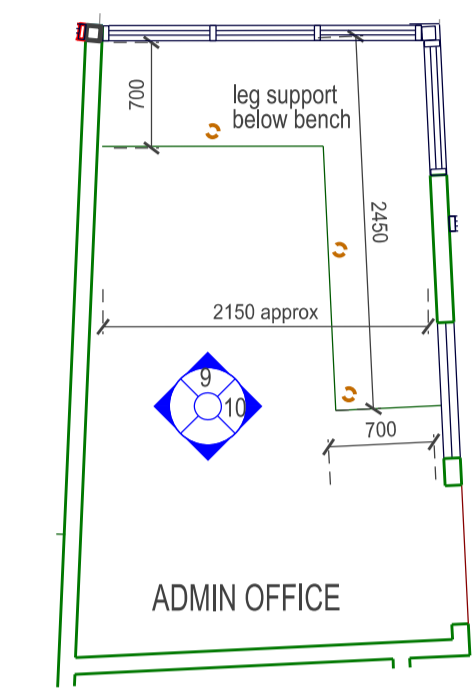
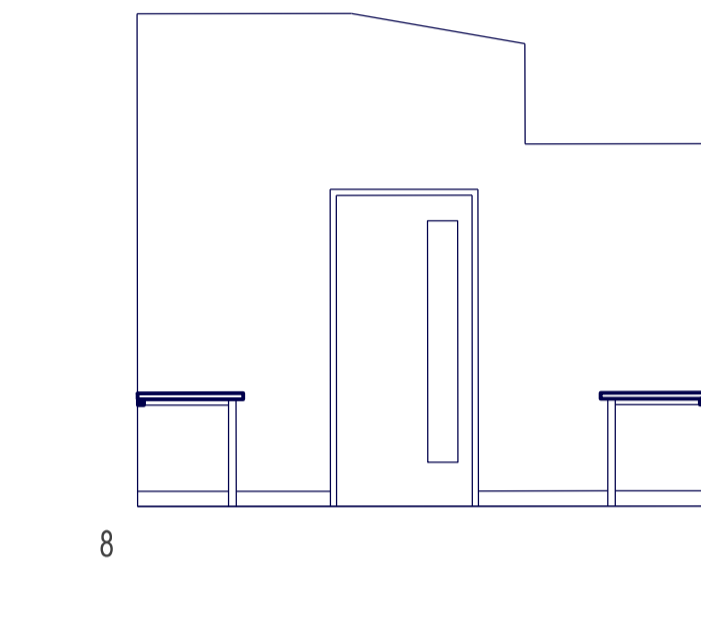
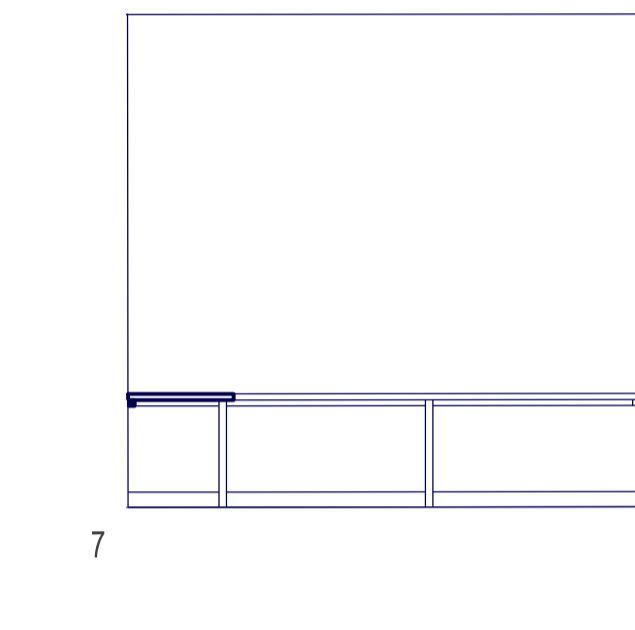
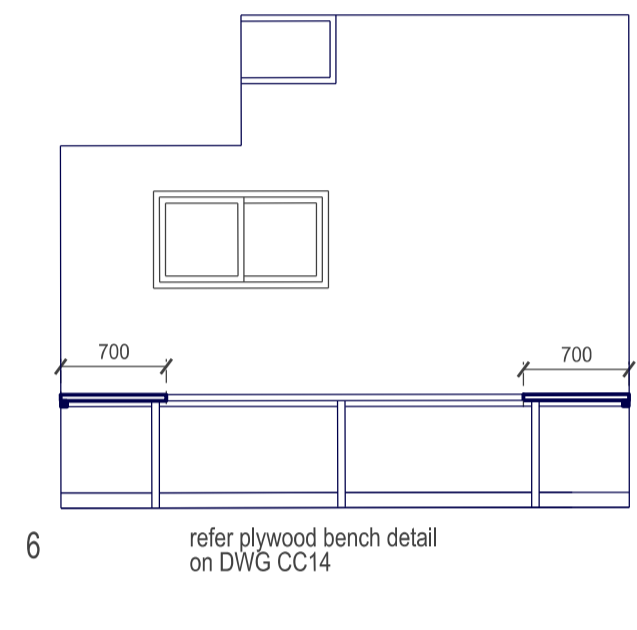
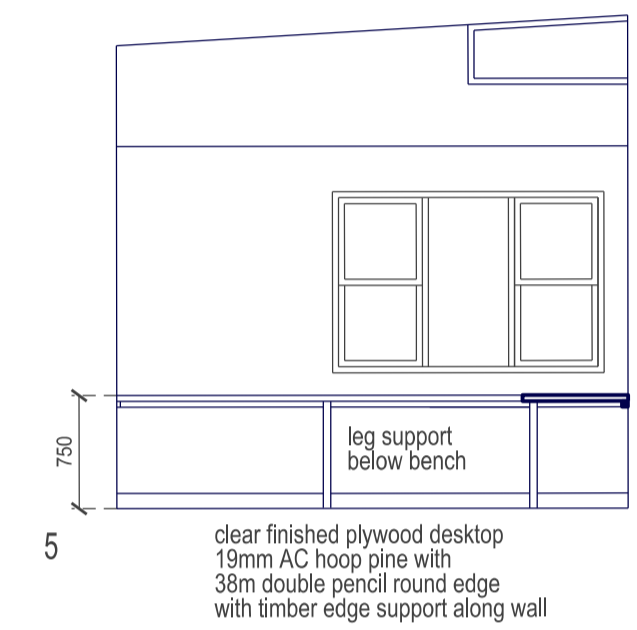
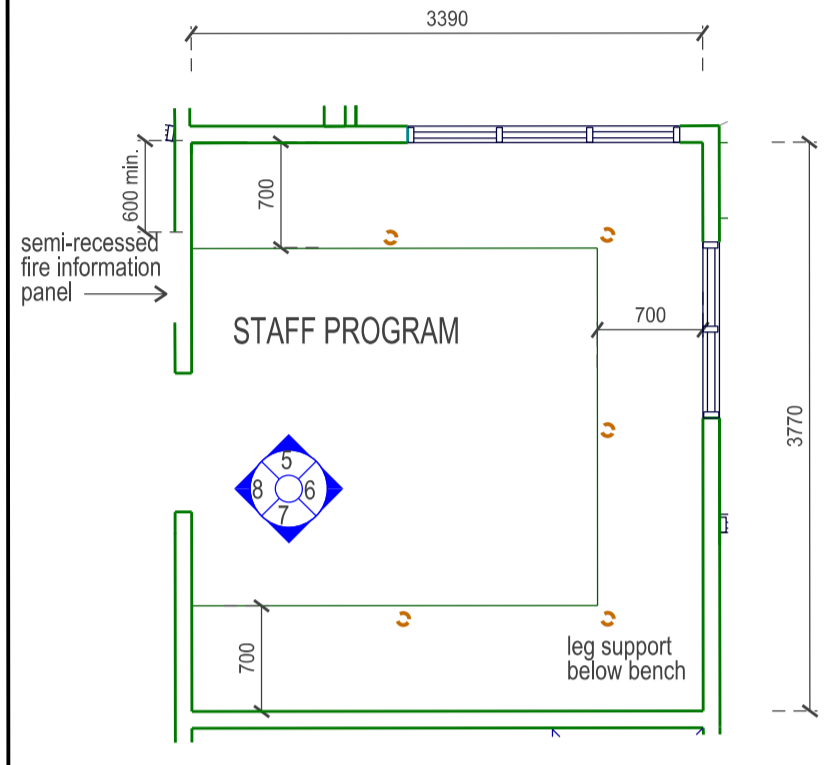

Dillon & Savage Architects
40 Quinton Rd, Manly, 2095
Phone: (02) 9977 3714 Fax: (02) 9977 8215
email: dsarchs@bigpond.net.au

Client
LEICHHARDT COUNCIL

Project
Proposed Child Care Centre
Leichhardt Park

Drawing
ROOM ELEVATIONS SHEET 2

| | | |
|------|-----------|--------------------------------|
| C | 16/7/15 | CONSTRUCTION ISSUE |
| B | 19/4/15 | Issued for tender |
| A | 23/3/15 | Issued for pre-tender estimate |
| Date | Amendment | |

| | |
|---------------------------------|---|
| Drawing No. 103 131 TD12 | |
| Issue C | Date March 2015 |
| Scale 1:50 @A1 | Drawn <input type="checkbox"/> Checked <input type="checkbox"/> |